

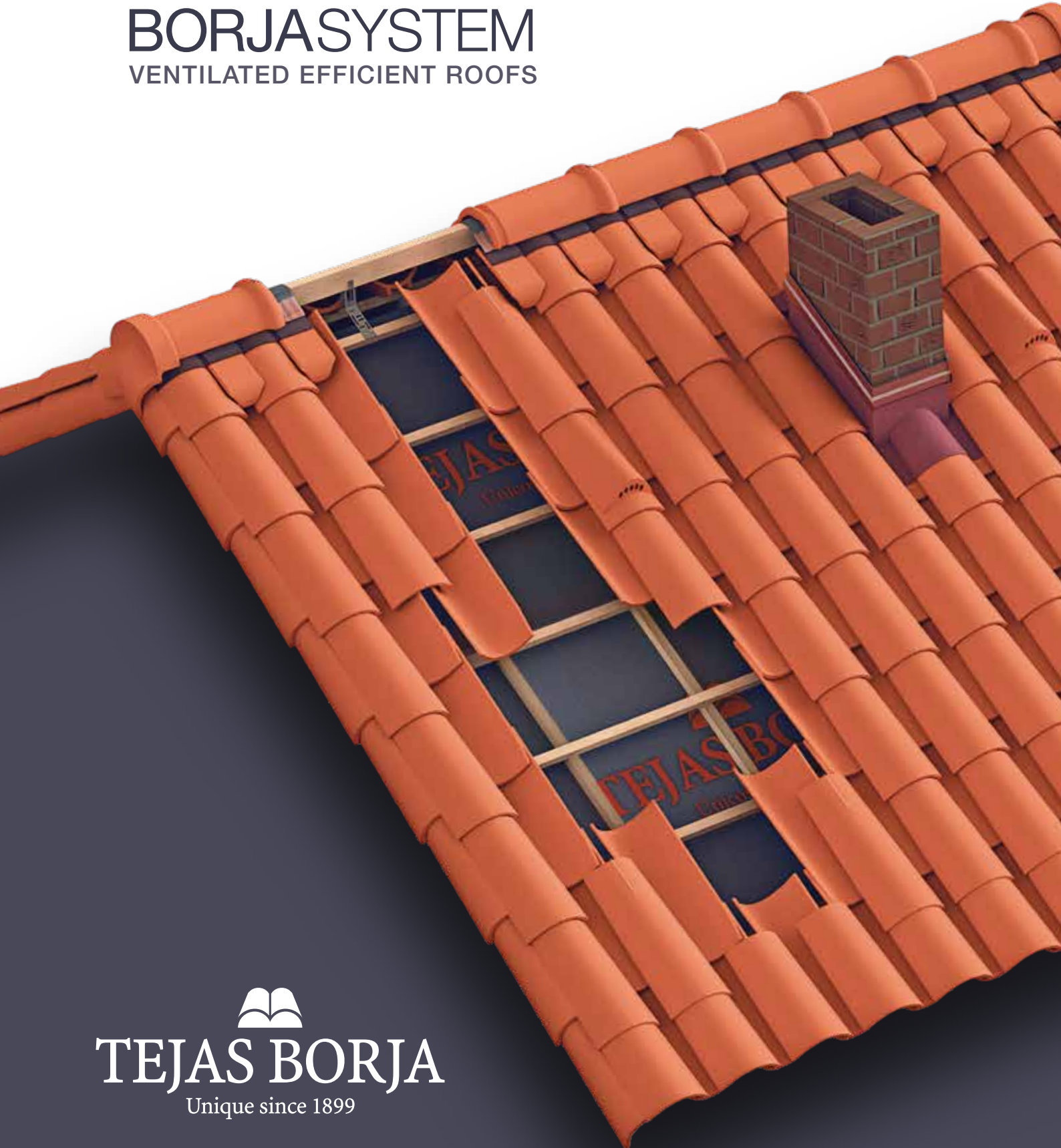

BORJASYSTEM

VENTILATED EFFICIENT ROOFS



TEJAS BORJA

Unique since 1899

NATURAL, VENTILATED ROOFS

CURVED TILE INSTALLATION SYSTEM

Through the ages different cultures have viewed the roof as something to protect the home from outside forces: a refuge or shield.

Today, in addition to continuing to provide cover, roofs have also developed to adapt to **new artistic ideas and efficiency standards**, two essential factors in roofing for modern society.

The need **to reduce energy consumption**, and CO² and greenhouse gas emissions to meet **Horizon 2020** energy objectives, has resulted in a shift in recent years towards the use of materials and systems in building coverings which improve insulation, thereby **reducing moisture** in walls and roofs, in accordance with the **Building Standards**.

A **BORJASYSTEM** ventilated roof, installed together with the corresponding layer of thermal insulation, improves the energy efficiency of the roof, playing an important role in reducing the heat which passes through the covering to inside the home.

This roofing system minimizes the chances of condensation forming in the thermal insulation and the materials of the exterior walls and roof, thanks to the use of waterproof and breathable membranes and the continuous circulation of air between the supporting structure and the tiles. The incorrect use of mortar causes the majority of problems experienced with sloping ceramic tile roofs:

- Damp and leaks.
- Structural overloading.
- Cracks and breaks in parts and joints.
- Lack of adequate ventilation.

The **BORJASYSTEM** installation system defines the criteria to be followed for a **complete dry installation** of the roof without the use of mortar.

When it comes to roofing, the correct installation of the system is as or more important than the material used to finish it.



ADVANTAGES OF THE SYSTEM



GREATER EFFICIENCY

increasing thermal and acoustic insulation, reducing energy consumption.



FROST RESISTANT

suitable for use in any climate.



BETTER VENTILATION

than that provided by other installation systems.



>50% LIGHTER

than installation with mortar.



PREVENTS CONDENSATION

caused by moisture in the roof (Spanish Technical Code, CTE DB-H1).

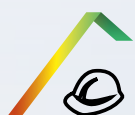

IDEAL FOR RESTORATION

of historic buildings due to the similarity of the materials to those used in traditional systems.



NATURAL PRODUCTS

wood and ceramics free from asbestos or any other toxic substances.



INSTALLATION GUARANTEE

for our tiles.



Roof Components INSTALLATION

TECHNICAL BORJASYSTEM

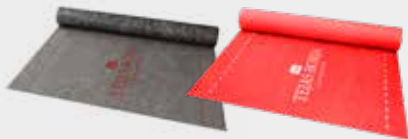
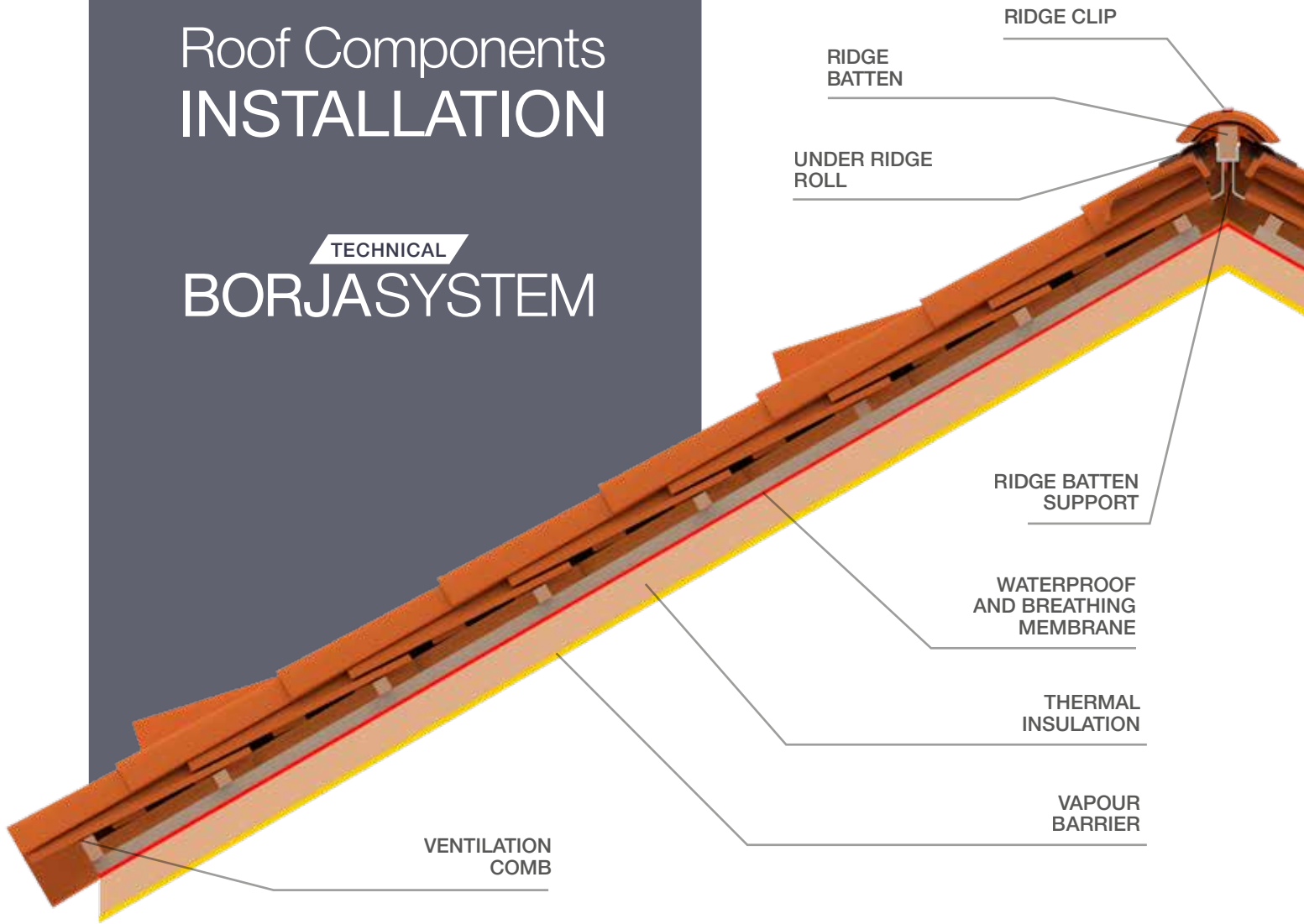

WATERPROOF AND
BREATHING MEMBRANE



VAPOUR
BARRIER



THERMAL
INSULATION



ROOFING
ADHESIVE TAPE



NAIL SEALING
TAPE

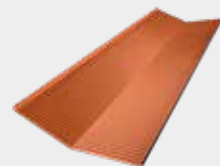

ALUMINIUM
ROOF VALLEY



MULTI-USE FLASHING
ADHESIVE BAND



COUNTER FLASHING
ALUMINIUM PROFILE



ROOF VALLEY
WEDGE





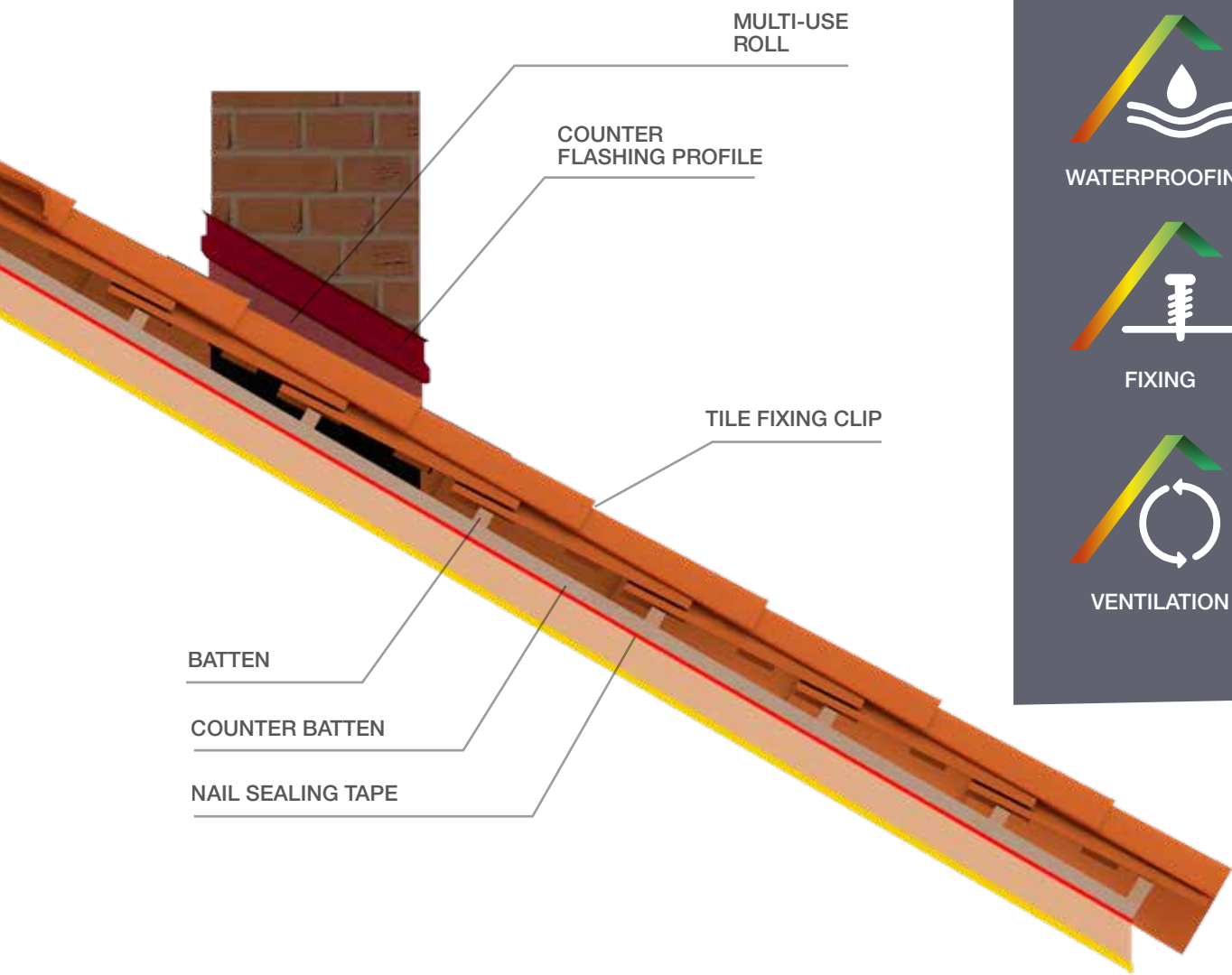





ROOF
VALLEY CLIP



WATERPROOFING

FIXING

VENTILATION

 ROOF BATTENS	 TILE FIXING CLIPS	 ROOF BATTEN SUPPORT	 RIDGE BATTEN 40 MM
 RIDGE CLIPS	 INOX. FIXING SCREWS	 ROOFING PU FOAM	 ADHSEIVE-SEALANT MS POLYMER

* Wooden battens can be replaced by metallic battens with a minimum height of 30 mm.

 VENTILATED RIDGE ROLL (MIXED, ALU OR TB-ROLL)	 EAVE COMB 100 MM	 EAVE GRATE 80 MM
--	---	---

ROOF TILES & ACCESSORIES

The necessary components for the correct installation of curved Celler® 50x21 tiles on a sloping roof are defined in this complete solution system.

The ceramic parts to be used in each instance are chosen according to the type of roof and the finials selected to finish its unique features.



Celler®
50x21

Step
Celler®
50x21



TB-12®



FLAT10

CURVED TILES



Celler® 50x21
Ventilation

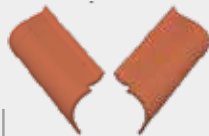

Universal Curved
Edge (Left/Right)



Cover+
Ridge



Universal
Under Ridge



Cover+
Hip Starter

AND
MANY
MORE*

Celler® 50x21 Step Celler® 50x21

Dimensions	500 mm x 210 mm / 170 mm	500 mm x 205 mm / 165 mm
Minimum pitch recommended	30% - 17°	30% - 17°
Weight	2,40 Kg/unit.	2,50 Kg/unit
Units / sq. m.	9 units	10 tiles
Useful length (Batten distance)	330 - 420 mm	330 - 420 mm



S-INTERLOCKING TILES



TB-12®
Ventilation



Universal Straight
Edge (Left/Right)



Circular
Ridge



Circular Hip
Starter



Universal Circular
Straight End Cap



Half TB-12®
Roof Tile

AND
MANY
MORE*

Dimensions	439 mm x 260 mm
Minimum pitch recommended	30% - 17°
Weight	3,15 kg/unit
Units / sq. m.	12,8 tiles
Useful length (Batten distance)	370 / 380 mm



FLAT TILES



Flat 10
Ventilation



Flat Straight
Edges (Left/Right)



Angular 100°
Ridge



Angular 100°
Straight End Cap

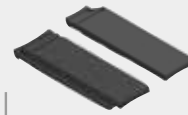

Half Flat 10 Roof Tile
(Left/Right)

AND
MANY
MORE*

Dimensions	451 mm x 287 mm
Minimum pitch recommended	35% - 19°
Weight	3,70 kg/unit
Units / sq. m.	11-10 tiles
Useful length (Batten distance)	350 mm - 380 mm



FITTING INSTRUCTIONS

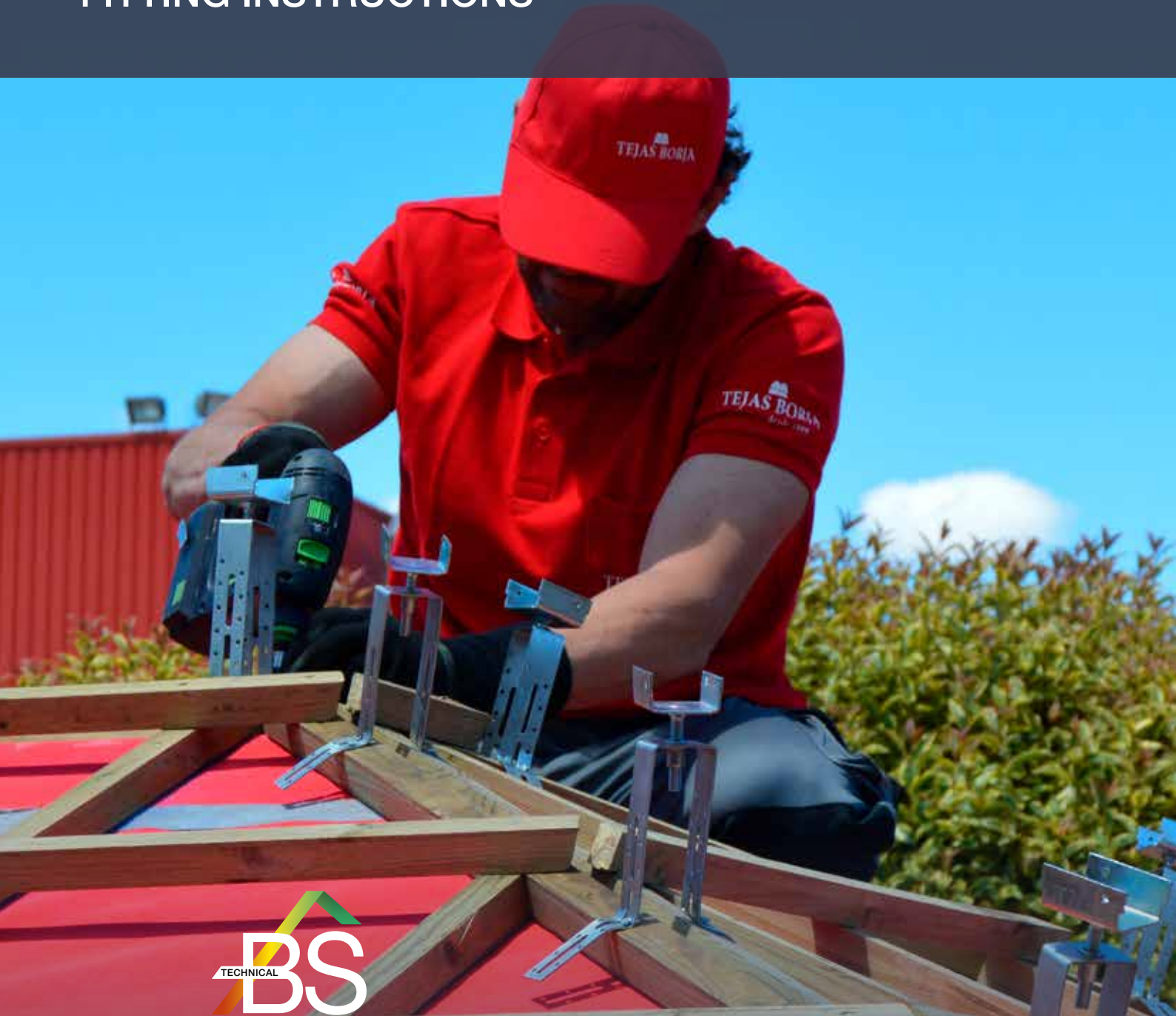

BORJASYSTEM

This guide has been designed to facilitate the installation of a high-quality, long-lasting roof which complies with Tejas Borja standards.

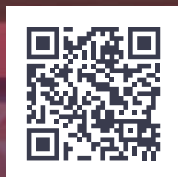

INSTALLATION VIDEO
S-INTERLOCKING TILES

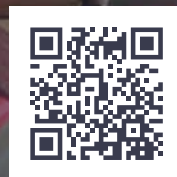

INSTALLATION VIDEO
CURVED TILES

PREPARING THE ROOF SLOPE

Once the underlying roof structure is complete, the roof will be built by first installing the **thermal insulation layer**, which can be made from various materials (such as polystyrene, mineral wools, polyurethane, reflective insulation and natural fibres).

The thickness of the insulation must be calculated depending on the climate zone where the roof is situated.

A **vapour barrier** is installed immediately below the insulation to restrict the passage of warm, moist air from inside the house to the roof insulation.

Once the thermal insulation is installed and correctly attached, the **waterproof, breathable membrane** is installed. The rows of membrane are laid to overlap each other by a minimum of 10 cm and in the direction of the slope, as shown by the pre-marked dotted lines. The ridges, valleys and hips must always be covered with membrane.

The joints are sealed with **membrane jointing tape** (Image 1).

When the membrane has been installed and sealed, the primary battens are installed in the direction of the roof slope. Before these are nailed in place, **protective tape** is applied to the underside of the battens (Image 2) to prevent leaks occurring around the nails.

Primary battens will be installed with a space of 40 to 70 cm between them.

The battens must be installed next to the joints in the valleys and on the hips as well as on the edges of the roof slopes. Once the primary batten structure is fixed in place, we will install the secondary battens which support the tiles, respecting the required batten spacing.

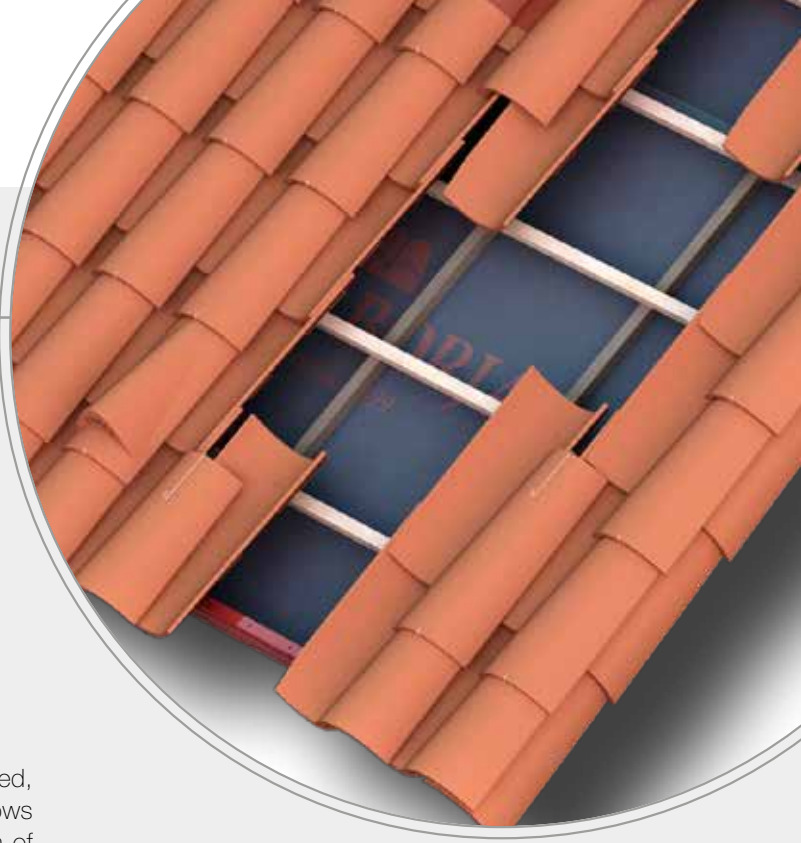

1



2

BATTEN FIXING ACCORDING TO SUPPORTING MATERIAL

Concrete	Nylon anchors and stainless steel screws (after drilling)
	Expansion anchor bolts (after drilling)
Wood	Stainless steel screws or nails.

Under-batten tape.

TILE INSTALLATION

The geography and climate of the area where the building is located must be taken into account when calculating the pitch of its roof, following Building Regulations and manufacturer's recommendations.

Depending on the pitch, more or fewer tiles will be fixed to the supporting structure. In the case of unique features such as eaves, edges, hips, valleys, joints and ridges, all tiles and special pieces must be fixed to the supporting structure at these points. The fixing methods used to install the tiles are only mechanical or chemical. Mortar is not suitable for BORJASYSTEM installations. In addition to screws and hooks, we use Tejas Borja **special foam for roofs** and our **hybrid polymer MS adhesive**.



DETAILS FOR CURVED TILES INSTALLATION

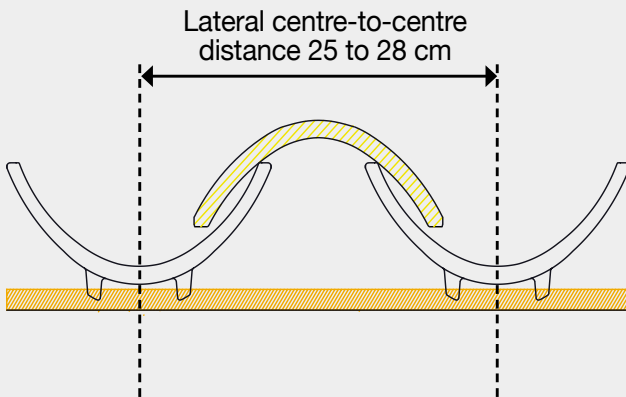

Roof tiles on the roof surface must be fixed to the support to a greater or lesser extent, depending on the pitch. In the case of singular points such as eave lines, edges, hip lines, valleys, joints and the ridge line, all roof tiles and accessories of these joints must be fixed to the battens.

We recommend that all roof tiles that form the perimeter of each skirt be fixed mechanically.

See the main Tejas Borja catalogue for information regarding minimum pitches of the roof depending of the tipe of roof tile used.



Pre-marked holes to secure the tiles in pan position.



EAVES

The first batten to be installed at the eaves must be at least 2 cm taller than the rest of the battens to maintain the roof gradient in the first row of tiles. To achieve this additional height, a taller batten can be used or a strip of wood can be added to a batten to make it taller than the others.

An **eaves filler comb** is installed on the eave batten to prevent birds and small animals entering the roof cavity while also ventilating the space.

The first row of tiles will overhang the facade by more than 10 cm and to a maximum of half the length of the tiles.

After reassessing the position of the tile rows on the roof slope, the first row of tiles will be placed in the pan position. This first row of tiles must be nailed to the batten; to make this easier the tiles come with a pre-drilled hole. To prevent the tiles at the eaves from being lifted by strong winds the front edges of the tiles are fixed to the batten/comb with spots of **Tejas Borja polymer adhesive**.

For curved tiles the first row of tiles in the cover position will be cut on the reverse side between 10 and 12.5 cm to create the seal between pans and covers. From this first row of tiles onwards, the overlap will be 12 cm, as this is the length of the fixing clips (Image 1).

These cut cover tiles are fixed with screws which are over 11 cm long to an **additional batten*** which will have been installed between the first and second battens so that it is in position to coincide with the holes in the tiles. The tile is pierced by drilling with a drill bit for ceramics (Image 2).

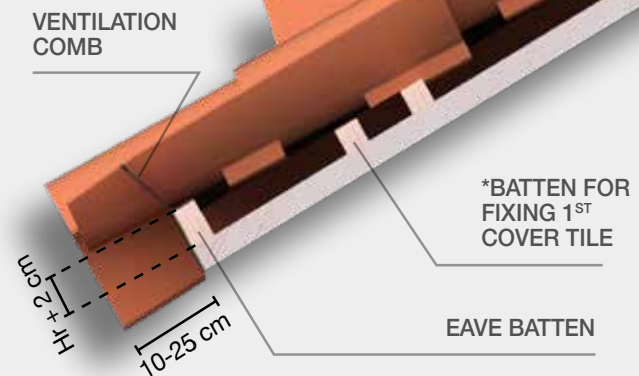

VALLEYS



To ensure the roof is waterproof, particular care must be given to valley installation. A valley is installed from the bottom of the slope to the top and before the roof tiles are fitted.

The supporting surface for the valley will be covered with a breathable, waterproof sheet, like the rest of the slope. When installing the battens, the pattern will be interrupted when reaching the bottom of the two slopes which meet at the valley.

- 1.- **Lacquered aluminium valley flashing sheets** are installed in the centre of the valley. The sheets overlap by a minimum of 15 cm from the bottom to the top of the slope. The pre-folded centre line is bent to form a drainage channel along the centre of the valley. The two edge lines are also bent inwards to prevent water from flowing over the sides of the valley. Moreover, the edges of the valley are protected by roof valley wedges, preventing water leaking into the roof due to splashing.
- 2.- Once the sheets have been centred and positioned over the joint, they are fixed to the batten using **valley clamps**. Alternatively, they will be fixed using screws, in which case the heads of the screws must be covered with Tejas Borja adhesive polymer to ensure the holes are waterproof.
- 3.- Once the valley is finished, the tiles will be placed in lines parallel to the centre of the valley. The tiles must overhang the valley by a minimum of 10 cm. The distance between roof slopes on either side of the valley must be at least 20 cm. All the pieces around the joint will be fixed to the battens with screws or clamps and with the help of Tejas Borja tile foam and adhesive polymer.



EDGES

The edges of the roof slopes will be finished with **edge finishing pieces**. These pieces can be straight or curved and are specially designed for these parts of the roof, made to be water resistant and fixed to the battens with screws.

In case of necessary to facilitate the installation of the edge pieces, another batten will be attached on the edge of the roof in the direction of the slope.

The edge finishing pieces must always be placed underneath the adjacent row of cover tiles, following the direction of the tile channel.

The exterior tile edge must overhang the facade by a minimum of 5 cm.

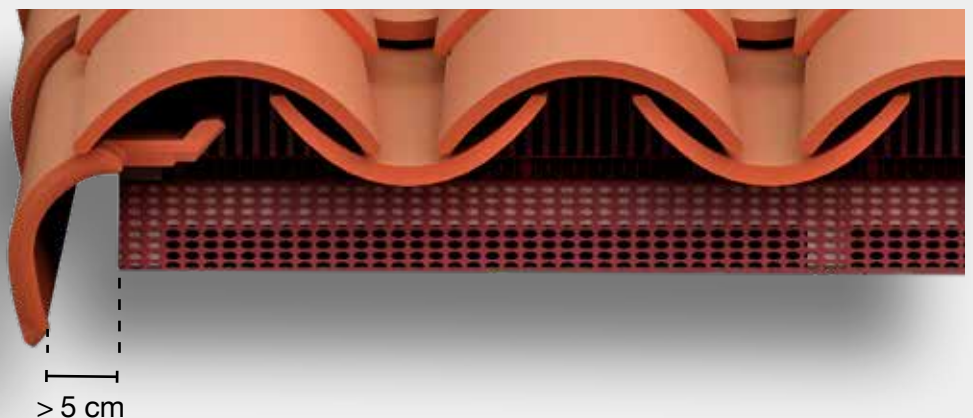

RIDGES AND HIPS

1.- The **ridge batten supports** (fixed or adjustable, as desired) are screwed to the apex of the roof slopes. The supports are bent to take on the same angle as the roof slope.

Then the supports must be levelled at the correct height so that when the ridge tiles are installed they mostly rest on the highest row of roof tiles and the ridge wedges. When the supports have been levelled they are fixed to the battens so they will not obstruct the installation of the tiles.

Once the ridge supports have been installed, the slope tiles and ridge wedges will be installed. The ridge batten is fixed mechanically to the batten supports which are placed at 40-60 cm intervals. The **ridge batten** is usually a 40x40 mm treated wooden strip.

2.- **Ridge tape** is installed over the ridge batten to seal and ventilate the ridge. Once centred, the tape is fixed to the ridge using staples or nails at various points along the length of the batten.

To waterproof the joint, the ridge tapes have two butyl adhesive strips on the underside on both edges of the tape. These strips must be fixed to the last row of tiles at the top of the roof slope and the ridge wedges (to ensure the butyl adheres correctly the surface must be clean and dry).

3.- Finally the ridge pieces are installed, fixed mechanically to the ridge batten with screws or **ridge clamps**. Depending on the roof type, various special pieces may be used to finish off the ridges such as **end caps**, **3-way ridge caps** and **hip starters**.

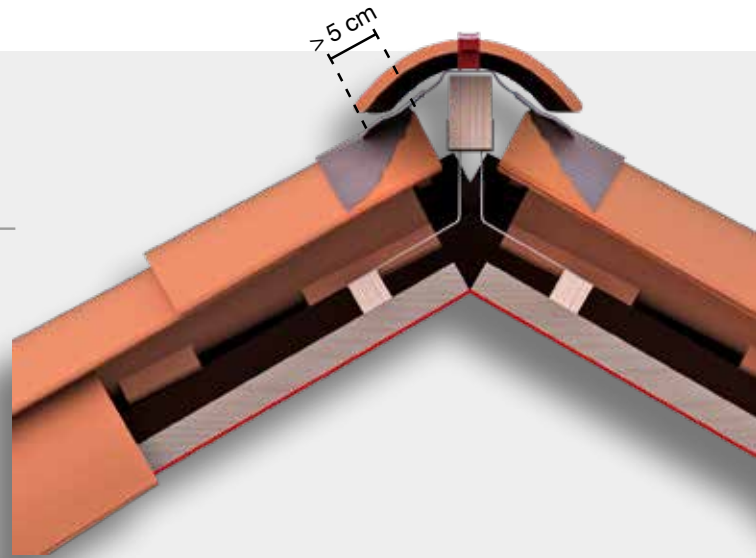

JOINTS WITH WALLS OR CHIMNEYS

There may be joints between the roof and upper or lateral walls or around chimneys and other protruding features.

Adequate sealing of these joints using **multi-use waterproof flashing tape** is critical to ensure the roof is fully waterproof:

1.- Once it has been cut to the required length, the waterproof tape is fixed to the wall using butyl adhesive. The surface to which the tape will be fixed must be free of dust and dirt, dry and sufficiently level.

The tape must be stuck at least 15 cm above the wall. The rest of the tape will adhere to the profile of the tiles at the joint to prevent water entering the roof.

2.- The **aluminium counterflashing profile** will be screwed to the upper part of the tape which has been stuck to the wall.

3.- Once the counterflashing profile has been installed, the upper edge of the profile will be filled with a **continuous line of Tejas Borja adhesive polymer** to guarantee a waterproof seal.



SPECIFIC CASES

Each roof is different and this is why they may have unique features such as changes in **pitch**, **hidden gutters**, **covered brackets** or **unusual joints** between various slopes.

Particular care must be taken when waterproofing the roof to guarantee the system is impermeable. To ensure the roof is watertight, special pieces must be used, or critical points must be sealed in situ using aluminium or zinc sheets or multi-use waterproof flashing.

If **windows** or **solar panels** are installed in the roof the manufacturer's guidelines must be followed and particular care must be given to achieving watertight seals.



ROOF MAINTENANCE

The accumulation of micro-organisms, moss, plants and other debris on tiles, valleys and gutters can impede the drainage of rainwater and the drying of roof tiles. This may lead to problems and cause leaks.

Roof tiles are made from a natural material and so should never be treated with any product which could alter their behaviour in adverse weather conditions.

The roof should be inspected regularly to check the condition of all its parts, ceramic elements, insulation, drainage channels, joints and its supporting structure. Damaged parts should be replaced or repaired whenever necessary. All ceramic parts and drainage channels should be cleared of any accumulated debris and moss so they do not obstruct the drainage systems. Regular roof inspections must be carried out every 1 to 3 years depending on the roofing material.





RAISE the Roof

A century around tiles

TEJAS BORJA, S.A.U.

Ctra. Llíria a Pedralba, Km. 3
46160 Llíria, Valencia, SPAIN
T: +34 96 279 80 16
F: +34 96 278 25 63
info@tejasborja.com

tejasborja.com



TEJAS BORJA
Unique since 1899

Distributor

